



DISCLAIMER

To avoid injury or damage to product only qualified personnel should install, operate or maintain MGM sample valves. It is imperative that any person working with the valve uses extreme caution and follows their company's policies while doing so. **Read all of these instructions carefully before proceeding.** All IOM instructions should be saved and reviewed per the company's required training frequency.

INSTALLATION

1. Inspect all threads for damage before installing to tank car. Both female and male threads should be free of any nicks, dings or deformations. If threads appear to be damaged, please contact MGM.
2. Apply PTFE tape or thread compound to the appropriate thread.
3. **CAUTION:** Do not overtighten valve to nipple. This could fatigue the pipe nipple threads.
4. Valve should be installed onto or into its mating thread using the appropriate wrench.
5. MGM sample valves are made entirely of 300 series stainless steel material. Please avoid painting the sample valve, which could impact the valve's operation in the future.

OPERATION

1. Remove 1/4" pipe plug from side port of valve.
2. Attach appropriate sampling equipment to outlet port.
3. Open valve counterclockwise to the desired position. Please note: the valve will start flowing commodity as soon as the valve handle has been turned. Full flow will be achieved after two to three complete turns.
4. Once the desired sample level has been achieved, hand tighten the valve to the closed position. **CAUTION: DO NOT USE A WRENCH TO CLOSE THE VALVE.** Overtightening could damage the PTFE seat, introducing the possibility of leakage in the future.
5. Inspect the 1/4" pipe plug for thread damage. Install the pipe plug using PTFE tape or thread compound, based on your company's policy.

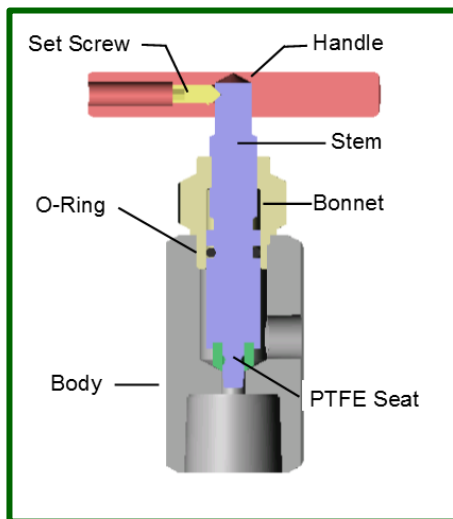

Model 330 Drawing

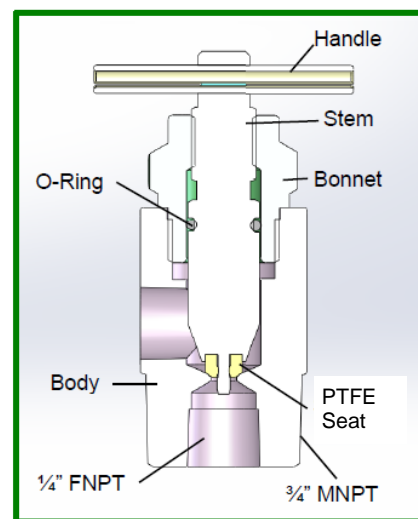

Model 331 Drawing



MAINTENANCE

Disassembly, Inspection and Cleaning

The packing O-rings used in the MGM sample valves are specified by the end user. MGM recommends changing packing O-ring periodically.

1. Secure the valve body in a vise.
2. Remove the bonnet (see diagram)
3. Remove the old O-ring, do not scratch the O-ring surface (see diagram)
4. Remove the PTFE seat (see diagram)
5. Clean Body, Bonnet and Stem in solvent removing any debris that may have collected on or in the valve parts.
6. Inspect all parts for obvious damage, if any part appears to be damaged please contact MGM for recommendations on how to proceed.

Reassembly of the Stem

1. Insert O-ring in the stem's O-ring groove
2. Press PTFE seat into the bottom of stem:
 - a. Hold PTFE seat in place with the angled side of the seat pointing down
 - b. Insert the protruding portion of the stem into the hole of the PTFE seat
 - c. Firmly push down on the top of the stem, seating the PTFE into the machined cavity
3. Add grease to stem thread
4. Add a small amount of thread paste to the male thread of the bonnet

Reassembly of the Valve

1. Ensure the stem of the closure assembly is in the open position
2. Screw the bonnet into the top thread of the body
3. Torque bonnet to the body at 20 ft-lbs
4. Remove excess paste from body bonnet assembly
5. Ensure valve easily opens and closes

Leak Test of the Valve

Pressure test the valve to the NDT Bubble leak test method your company has developed. If valve leaks please contact MGM for further instructions.